



Powering Business Worldwide

Eaton
Aerospace Group
Fluid & Electrical Distribution Division

Carter®
Ground Fueling Equipment

SM64017

May 2013

Applicable additional manuals:

SM64019 – 2” Unisex Coupling, Non-Valved

SM64020 – 2” Unisex Coupling, Valved

SM64031 – 3” Unisex Coupling, Valved

SM61154 - Dry Break Disconnect

UP64017 - Upgrade Instructions - CCR Nozzle

Closed Circuit Refueling (CCR) Nozzle

Model 64017

64017 Basic Nozzle - NSN 4930-01-363-6449

64017Z Arctic Nozzle - NSN 4930-01-370-3061

TABLE OF CONTENTS

	Page
1.0 INTRODUCTION.....	3
2.0 EQUIPMENT DESCRIPTION.....	3
3.0 DISASSEMBLY.....	5
4.0 INSPECTION.....	6
5.0 SPECIAL TOOLS.....	7
6.0 REASSEMBLY.....	7
7.0 TEST.....	8
8.0 TROUBLESHOOTING.....	10
9.0 ILLUSTRATED PARTS CATALOG.....	10
FIGURE 1 - OPTIONS VIEW.....	14
FIGURE 2 - PARTS BREAKDOWN.....	15
FIGURE 2A - MAIN BODY SEAL INSTALLATION.....	16
FIGURE 3 - ASSEMBLY TOOLS.....	17
FIGURE 4 - USE OF 220284 TOOL.....	18
FIGURE 5 - USE OF 220284 TOOL.....	19

**MAINTENANCE, OVERHAUL & TEST INSTRUCTIONS
MODEL 64017 CLOSED CIRCUIT REFUELING NOZZLE**

1.0 INTRODUCTION

This manual furnishes detailed instructions covering the operation, maintenance and overhaul of Eaton’s Carter ground fueling equipment product line Model 64017 Closed Circuit Refueling (CCR) Nozzle. It is designed in accordance with MIL-N-52747F(AT), Type I. The Arctic version, 64017Z, is designed in accordance with MIL-N-52747, Type II, Class A and MIL-N-53094. There are several options available when purchasing a unit as explained in paragraph 2.2 below.

The original nozzle was designed to utilize a diaphragm assembly as the main control element. The operation of the unit in the field in the dry condition, although not specifically required in the specification, tends to cause premature failure of the diaphragm causing external leakage. In addition, the specification does not address external leakage at any inlet pressure less than 5 psig although it is quite

common for the nozzle to be stored with less inlet pressure caused by “head” pressure only. In this condition, it has been found that leakage from the connecting end of the nozzle did result. A new pressure energized Teflon seal has been incorporated. The later nozzles, serial number 5804 and subsequent, all are equipped with both the piston assembly and Teflon seals.

If the nozzle to be overhauled is serial number 5803 or lower manual UP64017 will be required to explain the upgrade procedure. UP64017 is provided in any of the upgrade kits listed in paragraph 9.0 or it is available from our web site www.eaton.com or an Eaton Carter ground fueling equipment distributor. If the serial number is 5804 or the nozzle has previously been upgraded, only this manual is required.

2.0 EQUIPMENT DESCRIPTION

2.1 DESCRIPTION

Model 64017 CCR Nozzle and a closed circuit refueling receiver mounted in a vehicle fuel tank comprise a closed circuit refueling system. It is designed for fueling under pressure with optimum speed, minimum loss of fuel and safety. The refueling system is grounded and bonded and allows the vehicle to be refueled while engines are in operation without danger.

The CCR Nozzle is capable of functioning as an on-off valve, in addition to its pressure regulator capabilities. The CCR Nozzle pressure regulator device performs in conjunction with a closed circuit receiver orifice

to comprise a flow control unit. This unit allows fuel to enter the vehicle at a specified flow rate. A bonding cable is provided for discharge of any static electric charge. A strainer assembly is a part of CCR Nozzle inlet. The CCR Nozzle is designed to mate, also, with a Gravity Fill Adapter assembly (GFA), Model 64014 (MIL-N-52748) for standard service or 64033 (MIL-N-53093) for arctic service, for use in refueling vehicles that do not have the appropriate receiver.

2.2 OPTIONS AVAILABLE

Model 64017 CCR Nozzle is available with the options listed in the table below. This manual covers all such options.

TABLE OF OPTIONS

MODEL 64017 CCR NOZZLE

The basic model number 64017 may be modified to include the options shown below by adding the appropriate suffix letter(s) to the model number. The basic part number, 64017, is a CCR nozzle that meets the requirements of MIL-PRE-52747F(AT) (previously MIL-N-52747), Type I, tan in color, including a 100-mesh screen, 2” female camlock inlet fitting and 15 ft. bonding cable.

Option Letter	Description
A	Same as standard nozzle except the 2” camlock inlet fitting is not supplied
B	Same as standard nozzle except the 2” camlock inlet fitting is replaced by a non-valved unisex coupling, (64031922). This unit meets the requirements of MIL-N-52747, Type I, Class B, tan in color.
C	Standard nozzle with 100-mesh screen and housing less camlock inlet fitting. Inlet is 2” female NPT.
D	Same as standard nozzle except inlet screen housing and camlock fitting is replaced with a male adapter to interchange with underwing nozzles that mate with Model 61154 Female Half Dry Break QD. Includes 100-mesh screen.

Option Letter	Description
E	Same as "B" option except unisex coupling is valved (6432022).
F	Basic nozzle except replaces inlet camlock with 3" 64031 Unisex Coupling with 100-mesh strainer.
G	Add to basic, options B or E to conform to green color requirement of specification.
Z	Arctic service nozzle in accordance with MIL-N-52747, Type II, Class A and MIL-N-53094. Includes all the same features of the standard nozzle. Green color only available.

2.3 EQUIPMENT OPERATION

2.3.1 SAFETY INTERLOCKS

The control handle is a two-position (flow or open, "up" to no-flow or closed, "down") device which controls the flow of fuel through the nozzle. In normal operation, the handle should be in the closed and locked position. There is no lock in the open position. The nozzle control handle can be moved to the open position, once unlatched, however unless the nozzle is attached to the appropriate receiver, the nozzle will not open to allow flow. This interlock provides a safety feature to prevent inadvertent opening unless attached to the receiver.

- The flow control handle should be in the no-flow or closed (down) position to make it easier to attach the unit to the receiver. If the handle is in the open (up) position, immediate flow can result when the CCR Nozzle is attached.
- Attach the nozzle to the receiver with a straight push-on motion. A positive connection is indicated by the collar moving forward with an audible "click".
- Open unit by depressing side mounted latch and moving handle to open position (or up).

2.3.2 OPERATION INSTRUCTIONS

To commence the actual refueling operation, the CCR must first be attached to a receiver, then the side mounted latch must be depressed and then the flow control handle can be moved to the open position (or up). An emergency disconnect during the fueling operation may be accomplished at any time by simply pulling the collar away from the receiver. The flow control handle will remain in the up position but the CCR will automatically close.

A red colored pin is provided to serve as a visual indication of the nozzle being in the closed or no-flow position. This pin extends or retracts into the housing at the flow control handle end.

Operation of the CCR Nozzle should be as follows:

- Insert ground plug into vehicle and/or attach alligator clip to unpainted metal on vehicle. Do not attach to propeller or radio antenna. Nozzle and vehicle are now bonded and grounded.

NOTE

Completion of filling is controlled by the vehicle control valves. Extension of the red indicator pin indicates closure of the nozzle regulator valve. The nozzle may cut on and off to top off tanks where vehicles use multiple fuel tanks.

- Return handle to the no-flow or closed (down) and latched position.
- Disconnect nozzle from receiver by pulling on collar in a motion away from vehicle. Disconnect vehicle grounding plug and/or clip. Replace dust cap in coupling end of nozzle.

2.3.3 PREVENTATIVE MAINTENANCE CHECKS - EACH REFUELING OPERATION

The following checks should be accomplished before each refueling operation:

- Ascertain that the flow control handle is in the no-flow or closed position (down).
- After removing dust cap and before attaching nozzle to receiver, check the coupling end of the nozzle to assure that there are three stayback lugs and nine locking lugs visible. If any are missing, the nozzle should not be utilized before it is repaired.
- There should be no external leakage from any place on the nozzle or the connection to the hose.
- The bonding cables should be present and not frayed or damaged in any way. The grounding plug and clip should not be damaged in anyway.

WARNING!

Grounding must be accomplished before making contact of nozzle to vehicle.

- Remove dust cap from nozzle coupling end by pulling on collar in a motion away from the dust cap. The locking lugs will be positioned to allow the dust cap to be removed. The stayback detents will keep the collar in the pulled back position. It will be in a position to be installed onto the vehicle receiver.

3.0 DISASSEMBLY

Refer to Figures 1 and 2 for the item numbers listed in the text below. (Items with a prefix of "1-" are in Figure 1 and those with a prefix of "2-" are found in Figure 2.

3.1 BONDING CABLE ASSEMBLY (2-1)

To remove Bonding cable Assembly (2-1) first remove Screw (2-2). This will separate Plug Cable Assembly (2-4) and Clip Cable Assembly (2-3) from unit.

3.2 DUST PLUG ASSEMBLY (2-5)

The cable attachment for the Dust Cap Assembly (2-5) is removed when the above Bonding Cable Assembly (2-1) is removed. To remove the Dust Cap Assembly (2-5) from the nozzle, pull back on the Collar (2-32) to release it. Dust Cap Assembly (2-5) is provided only as an assembly and further disassembly is not needed.

3.3 WIPER SEAL (2-6)

With the flow control handle in the closed position, reach inside the coupling end and remove and discard the Wiper Seal (2-6). See note in Table 2, Section 9.0 under item 2-6 for more information on this part.

Push the Piston Compression Tool, part number 220283, into the coupling end of the nozzle until it latches.

3.4 COUPLING END OF NOZZLE

Before proceeding further be sure that the opening handle is in the "open" position.

With the Piston Compression Tool, 220283, still installed in the nozzle, use the Poppet Tool, 220329, to remove the Poppet (2-14).

While holding the Piston Compression Tool 220283, pull back on the Collar (2-32) to release and remove the Piston Compression Tool 220283, Seal Sleeve (2-30), Spring (2-31) and Flow Guide (2-50). Discard Seal Sleeve (2-30).

Generously apply isopropyl alcohol between Collar (2-32) and Housing (2-34) to lubricate threads. Use the Body Wrench, part number 220281, to remove Body (2-34) from Housing (2-15). Maintain pressure on wrench to prevent force of actuating springs from causing a sudden separation of parts when the threads of the Body (2-34) are disengaged from the Housing (2-15). Also, when turning the Body Wrench 220281, lightly pull back on the Collar (2-32) such that the Body (2-34) can rotate easily relative to the Collar (2-32).

The Collar (2-32) can then be removed along with the remainder of the bits and pieces, including three Stayback Detents (2-33), nine Locking Lugs (2-36), Lug Wire (2-35), Lug Retaining Ring (2-37), Stay Back Spring (2-38), Spring Retainer Ring (2-39) and Spring

(2-40). Care should be exercised so as not to lose the Stayback Detents (2-33) and Locking Lugs (2-36). Remove and discard Packing (2-41) from Housing (2-15). Remove and discard Seal (2-6B) and Backup (2-6A) from Body (2-34).

3.5 FLOW CONTROL LATCH END OF NOZZLE

Compress the Valve Actuator Latch (2-24) and place the flow control handle in the open (up) position. Remove four Screws (2-7) from End Cover (2-9). Do not remove Screw (2-7) from Cover (2-9) unless either the Locking Pin (2-10) or the Screw (2-7) are to be replaced. If these parts are to be disassembled, use a soft jaw chuck or vice to hold the Locking Pin (2-10) while removing the Screw (2-7). Regulator Spring Retainer (2-11) and Regulator Spring (2-12) can then be removed. Pull Piston (2-13) with its attached parts from the unit. Remove the four Screws (2-26A) retaining the Bushing (2-26). This ring can be reused by reversing it and reinstalling it onto the Piston (2-13). Once it has been used on both sides, discard Bushing (2-26). Unscrew Nut (2-13B) to remove Seal (2-13A). Discard Seal (2-13A). Unscrew Position Indicator (2-29) from Piston (2-13) if it is to be replaced.

Remove four handle Screws (2-7) and Valve Actuator Handle (2-17).

Remove six Screws (2-27) and Sleeve (2-28). Remove and discard O-ring (2-28A).

Remove Screw (2-18) from one side of the unit. This allows the removal of Side Plate (2-21), two Washers (2-19) and Bushing (2-20). Screw (2-22) and Actuating Cam (2-23) should not be removed from Side Plate (2-21) unless one is damaged and replacement is needed. If replacement is needed, use a soft jaw chuck or vice to hold Actuating Cam (2-23) while removing Screw (2-22).

Note: When removing Side Plate (2-21) from the side of the unit where the Valve Actuator Latch (2-24) is located, compress the Valve Actuator Latch (2-24) for the removal. Then the Valve Actuator Latch (2-24) and Detent Spring (2-25) can be removed from the Housing (2-15).

3.6 INLET STRAINER HOUSING - 64017, 64017B, C & E only

Unscrew Strainer Body (2-45) from unit to inspect or remove Strainer (2-44). There is no need to disassemble Strainer Housing (2-42) from Housing (2-15) unless repair or replacement is needed. Packing (2-43) and Strainer (2-44) can then be removed. Discard Packing (2-43). It is not necessary to disassemble Coupling Half (2-48) or Unisex Couplings (1-4) or (1-10) from Strainer Body (2-45) unless repair or replacement is

needed. Gasket (2-47) can be replaced by removing Plug (2-49). Discard Gasket (2-47).
 3.7 NON-VALVED UNISEX INLET - 64017B Only (1-4)

Refer to Service Manual SM64019 (64319) for maintenance instructions for this part of the unit.

3.8 UNDERWING INTERCHANGE MALE ADAPTER INLET - 64017D Only (1-5)

Refer to Service Manual SM61154 for maintenance instructions for this part of the unit. Strainer (1-7) can be removed for inspection

and/or replacement by removing Retainer (1-8). Do not remove Adapter (1-6) from unit unless repair or replacement is needed.

3.9 VALVED UNISEX INLET - 64017E Only (1-10)

Refer to Service Manual SM64020 (64320) for maintenance instructions for this part of the unit.

3.10 VALVED UNISEX INLET – 64017F Only (1-10A)

Refer to Service Manual SM64031 for maintenance instructions for this part of the unit.

4.0 INSPECTION

4.1 PARTS REPLACEMENT

Replace the following items with new parts, available in the various kits listed in Section 9.0, during maintenance:

Item no.	Part no.	Name	Quantity	Used on
2-6***	201201-134	Seal	1	All
2-6A	220778	Backup	1	All
2-6B	220779	Seal	1	All
2-13A	221567	Seal	1	All
2-20	220101	Bushing	2	All
2-28A	MS29513-125	O-ring	1	All
2-30	220083-1	Seal	1	All but Z
2-30	220083-2	Seal	1	Z
2-41	MS29513-136	Packing	1	All
2-43	MS29513-226	Packing	1	All
2-47	MS27030-6	Gasket	1	All but Z
2-47	220126-6	Gasket, Arctic	1	Z
*	200146	Seal, Unisex	2	B, E
*	MS29513-010	O-ring	1	B, E
*	MS29513-136	O-ring	1	B, E
*	MS29513-226	O-ring	1	B, E
*	MS29513-228	O-ring	1	B, E
*	220157	Seal, Upstream	1	E
*	47363	Seal Assembly, Downstream	1	E
*	MS29513-014	O-ring	1	E
*	MS29513-133	O-ring	1	E
*	MS29513-134	O-ring	1	E
*	MS29513-009	O-ring	1	F
*	220465	Seal	1	F
*	220467	Seal	1	F
*	MS29513-234	O-ring	1	F
*	MS29512-03	O-ring	1	F
*	MS29513-016	O-ring	1	F
*	MS29513-016	O-ring	1	F
**	221266	Seal	1	D

* Items from SM64019, SM64020 or SM64031 that are not shown in this manual.

** Item from SM61154 that is not shown in this manual.

*** See note in Table 2, item 2-6 for more information on this item.

4.2 GENERAL INSPECTION

Inspect all metal parts for dings, gouges, abrasions, etc. Use 300 grit paper to smooth and remove sharp edges. Replace any part with damage exceeding 16% of local wall thickness. Use alodine 1200 to touch up bared aluminum.

4.3 DETAIL INSPECTION4.3.1 BONDING CABLE ASSEMBLIES

Inspect Cables (2-3 & 2-4) for signs of unraveling, wear or other damage. Inspect plug and clip for possible damage. Replace any worn parts as required.

4.3.2 DUST CAP ASSEMBLY (2-5)

Inspect Dust Cap Assembly (2-5) for cracks or other damage, check wire for fraying or other damage. Replace as required.

4.3.3 STAYBACK DETENTS (2-33) & LOCKING LUGS (2-36)

Inspect the Stayback Detents (2-33) and Locking Lugs (2-36) for cracks or broken pieces.

4.3.4 BUSHING (2-26)

Inspect Bushing (2-26) for wear or damage to both sides of the part. Replace or install in the reversed direction from any apparent wear as needed.

4.3.5 SLEEVE (2-28)

Inspect inside diameter for scratches that may cause leakage. Do not attempt to polish this part. Replace if scratched.

5.0 SPECIAL TOOLS

The following special tools are recommended for proper repair and or overhaul of the nozzle:

- 220281 Body Wrench
- 220283 Piston Compression Tool
- 220284 Locking Lug Assembly Tool

- 220329 Poppet Tool

The above tools are available on special order from a Carter distributor or directly from the factory. All four tools can be ordered as a single kit under part number KD64017-12.

6.0 REASSEMBLY

Reassemble the nozzle in the reverse order of disassembly taking note of the following items:

6.1 INLET FITTINGS

Refer to the appropriate Service Manuals, listed on the front cover for information regarding the assembly of the various inlets, if the unit is other than the basic 64017 or option C.

If the Strainer Housing (2-42), Coupling Half (2-48), Underwing Nozzle Interchange Adapter (1-5), Unisex Couplings (1-4) or (1-10) were removed for replacement or repair they must be reinstalled with a thread seal. If Teflon tape is utilized, **no more than one and on-half wraps** of tape should be used otherwise damage to the mating parts may occur. Any fuel resistant paste seal is acceptable.

Although available as a separate spare part, Gasket (2-47) is also furnished as a part of the Coupling Half Assembly (2-48).

6.2 FLOW CONTROL LATCH END OF NOZZLE

Place O-ring (2-28A) into the groove in Sleeve (2-28) and assemble into Housing (2-15) using Screws (2-27). Torque the Screws (2-27) to 23 in-lbs.

Screw Position Indicator (2-29) into the Piston (2-13). Place Seal (2-13A) onto threaded end of Piston (2-13) with the open end (spring shows through it) facing toward the treaded

end. Screw Nut (2-13B) onto Piston (2-13) and torque in place to 125 in-lbs.

Slip Bushing (2-26) over small end of Piston (2-13) and attach to the flanged end with four Screws (2-16A). Tighten screws sufficiently to seat the Ring (2-26) only, do not over tighten.

Using a soft jaw chuck or vise, assemble the Actuating Cam (2-23) on one of the Handle Side Plates (2-21). Affix in place with Screw (2-22) and torque to 100 ± 10 in-lb. Repeat with the other set of similar parts. Start with the side of the Housing (2-15) that does not include the Valve Actuator Latch (2-24). Position Actuating Cam (2-23) into banana shaped slot in Housing (2-15) such that the Actuating Cam (2-23) is positioned between the Bushing (2-26) and the Sleeve (2-28). It will be necessary to attempt assembly with the Handle Side Plate (2-21) positioned in nozzle open position to achieve proper assembly. Place a Washer (2-19) between the Handle Side Plate (2-21) and the Housing (2-15). Insert Bushing (2-20) into the Handle Side Plate (2-21). Place a Washer (2-19) on the outside of the Handle Side Plate (2-21) and affix parts to unit using Screw (2-18). Torque to 125 ± 10 in.-lb.

Insert Spring (2-25) into cavity of Housing (2-15) followed by the Valve Latch Actuator (2-24). Holding this in the approximate position, repeat the assembly of the Handle Side Plate (2-21), Washer (2-19), Bushing (2-20), second

Washer (2-19) and Screw (2-18). Torque to 125 ± 10 in.-lb.

Place Valve Actuator Handle (2-17) between the two Handle Side Plates (2-21) and secure with four Screws (2-7). Torque to 35 ± 5 in.-lb.

If the Lock Pin (2-10) was disassembled from the End Cover (2-9) use a soft jaw chuck or vise to reinstall using Screw (2-7). The Lock Pin (2-10) will be assembled into one of the two holes provided in Piston (2-13). It will be necessary to rotate in Piston (2-13) to position one of the holes into the proper position.

Place End Cover (2-9) temporarily in place to check the location of the hole in the in Piston (2-13) with respect to the Lock Pin (2-10).

Install the Spring (2-12) and position the Reducer Spring Retainer (2-11) over the Position Indicator (2-29). Install the End Cover (2-9) and Lock Pin (2-10) assembly such that the hole in the in Piston (2-13) accepts the Lock Pin (2-10). Tighten in place using the four Screws (2-7), torquing sufficiently to retain in place.

Rotate handle to closed position to check that everything was assembled correctly. Leave the handle in this position for the next assembly operation. Note: Moving the handle to the open position while performing the next operation may result in damage to the Lock Pin (2-10).

Insert Flow Guide (2-50), Spring (2-31) and Sleeve Seal (2-30) into the opposite end of the Housing (2-15). Insert the Piston Compression Tool, 220283, into the unit to hold the Sleeve Seal (2-30) away from the Poppet (2-14) when it is installed.

With the Piston (2-13) held in place by the Lock Pin (2-10); thread Poppet (2-14) into the opposite end of the Housing (2-15) and tighten securely in place using Poppet Tool 220329.

NOTE: Do not remove the Piston Compression Tool, 220283, until the nozzle is fully reassembled.

At this point, the Piston Compression Tool, 220283, can be removed from the nozzle by pulling back on the Collar (2-32).

6.3 COUPLING END OF NOZZLE

Install Backup (2-6A) into the inside groove closest to the threaded end of the Body (2-34). The Backup (2-6A) is split to facilitate installation. Note that the thin lip part of the Backup (2-6A) faces the threaded portion of the Body (2-34). Then install the Seal (2-6B) into the groove left adjacent to the Backup (2-6A). The open end containing the spring must face the threaded end of the Body (2-34). See Figure 2A for installation details. Smooth the

Seal (2-6B) with a finger to assure that it is fully installed and to remove any wrinkles.

Install Packing (2-41) into groove in Housing (2-15) making sure that it is smoothly installed.

Referring to Figure 4, install Lug Wire (2-35) onto the groove in the nose of the Body (2-34). Insert this assembly into the Lug Assembly Tool, 220284. The Lug Assembly Tool should be placed into a vice during this operation. Insert the three Stayback Detents (2-33) into the spaces in the Body (2-34) being sure to space the Stayback Detents (2-33) into every fourth space. Referring to Figure 5, insert the nine Locking Lugs (2-36) with three Locking Lugs (2-36) between each pair of Stayback Detents (2-33). Slide Lug Retainer Ring (2-37) and Spring (2-38) onto the Body (2-34) being sure that the chamfered end of Lug Retainer Ring (2-37) is placed downward toward the Locking Lugs (2-36). Slide the Collar (2-32) over the assembly and work it down over the Locking Lugs (2-36) and Stayback Detents (2-33).

Install Spring Retainer Ring (2-39) and Spring (2-40) into the above assembly.

Slide the Housing (2-15) onto the above assembly. Push down on the Housing and rotate the Housing clockwise about one turn to start the threads between the Body (2-34) and Housing (2-15) and make sure that the notch in the Collar (2-32) lines up with the protrusion on the Housing (2-15) after the one turn.

Remove nozzle assembly from the Lug Assembly Tool, 220284, and place Housing (2-15) in a vise so that the nozzle assembly is facing upward. Using Body Wrench, 220281, tighten the assembly to 250 in.-lb. torque to seat the unit snugly. When turning the Body Wrench 220281, lightly pull back on the Collar (2-32) such that the Body (2-34) can rotate easily relative to the Collar (2-32).

On all nozzles with serial numbers 7757 or lower go to 6.3.1, On nozzles with higher serial numbers or where a Body (2-34) has a narrow groove go to 6.3.2.

6.3.1 Install Seal (2-6) with a Backup Ring (6-A) in the wider groove. The order of installation is optional.

6.3.2 Install Seal (2-6) in the narrow groove.

6.4 BONDING CABLE ASSEMBLY (2-1) & DUST CAP ASSEMBLY (2-5)

Attach the Bonding cable Assembly (2-1) and Dust Cap (2-5) to the Housing (2-15) using Screw (2-2). It is recommended that the Bonding cable (2-1) be placed next to the Housing (2-15) to gain better electrical conductivity.

7.0 TEST
The following test procedures will be accomplished after overhaul:

7.1 TEST CONDITIONS

Test media shall be JP-4, Jet A or odorless kerosene, commercial solvent 140.

7.2 FUNCTIONAL TEST

- Install nozzle in test rig, 70007, in accordance with Figure A. Open nozzle and Valve 8 to recirculate the test fluid through the system to bleed all trapped air.
- ! Increase inlet pressure to 25 psig and close Valve 8. The visual flow Indicator (2-29) should be visible indicating that the unit had also closed. Close the nozzle with the flow control handle.
- Open Valve 8 and increase the inlet pressure to 125 psig. Slowly open the flow control handle. Adjust the flow rate by restricting Valve 8 to maintain the inlet pressure at 125 psig. Close Valve 8 and check to see that the nozzle has closed (visual Indicator (2-29) visible). Close the nozzle and disconnect from the system.

7.3 CONTINUITY TEST

With nozzle removed from the test rig install Coupling Half Plug (2-49). Check continuity across the following locations on the nozzle.

- Locking Lugs (2-36) and Grounding Clip (2-3).
- Locking Lugs (2-36) and Grounding Plug (2-4).

7.4 PROOF PRESSURE

- With the nozzle closed and not connected to the test system, apply 5 psig inlet pressure for one minute minimum. There shall be no leakage.
- Slowly increase the inlet pressure to 180 psig for one minute minimum. There shall be no leakage or other damage to the nozzle.
- Connect the nozzle to the test system and open the nozzle with Valve 8 closed. Repeat the above two tests.

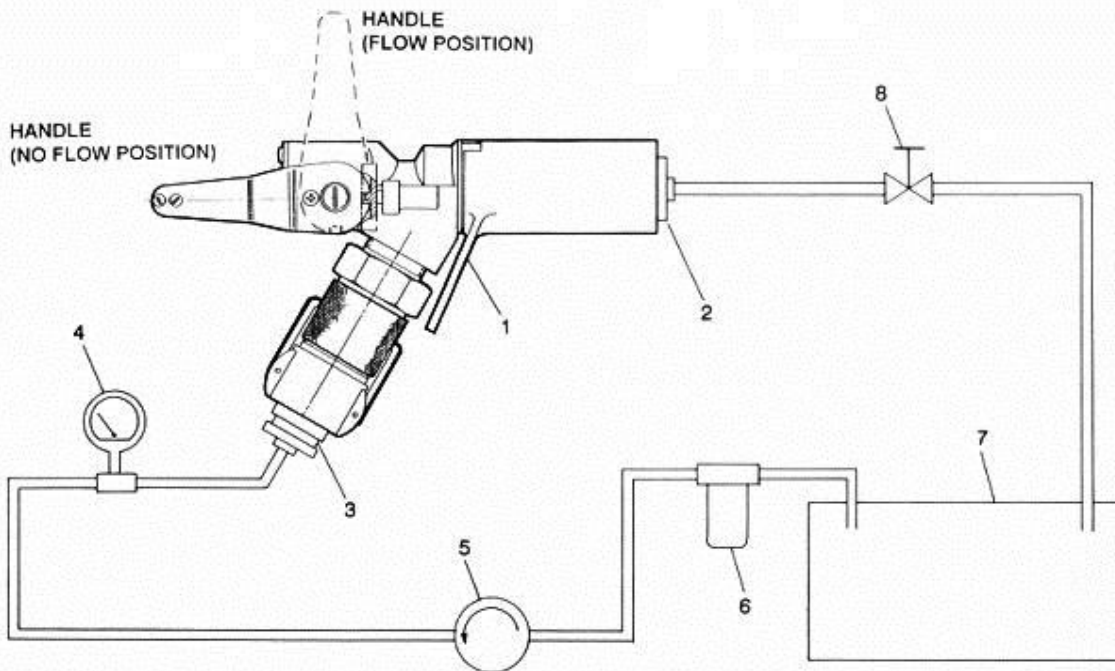

1. Nozzle assembly
2. Test adapter, outlet (note 1)
3. Test adapter, inlet (note 1)
4. Pressure gauge, 0-300 psig
5. Hydraulic pump, 0-300 psig
6. Filter, 15 micron
7. Fluid reservoir, 10-20 gallon
8. 3/4" ball valve

NOTES:

1. 3/4" NPT tapped hole in both adapters for hose connections.
2. ITEMS 2-7 may be procured as 70007 test system.

**FIGURE A
TEST SETUP**

Fig	Item	Part Number	Description	Units / Assy	Used on Option	Spares/10 units/Yr	
2	13	220768	Piston	1	All	-	
	13A	221567	Seal	1	All	10	
	13B	220777	Nut	1	All	-	
	14	220088	Poppet	1	All	-	
	15	220078-1	Housing, Tan	1	All but G, Z	-	
	15	220078-2	Housing, Green	1	G,Z	-	
	16	Left intentionally blank					
	17	220095-1	Handle, Tan	1	All but G, Z	-	
		220095-2	Handle, Green	1	G, Z	-	
	18	LP51957-108	Screw	2	All	-	
	19	5710-179-60	Washer	4	All	-	
	20	220101	Bushing	2	All	20	
	21	220090-1	Side Plate Handle, Tan	2	All but G, Z	-	
		220090-2	Side Plate Handle, Green	2	G,Z	-	
	22	GF16998-42L	Screw	2	All	-	
	23	220109	Actuating Cam	2	All	-	
	24	220202	Valve Latch Actuator	1	All	-	
	25	C0180-026-1000S	Spring	1	All	-	
	26	220769	Bushing	1	All	5	
	26A	GF16997-20L	Screw	4	All	-	
	27	GF16997-21L	Screw	6	All	-	
	28	220767	Sleeve	1	All	5	
	28A	MS29513-125	O-ring	1	All	10	
	29	220160	Position Indicator	1	All	-	
	30	220083-1	Sleeve Seal	1	All but Z	10	
		220083-2	Sleeve Seal, Arctic	1	Z	10	
	31	220112	Spring	1	All	-	
	32	220081-1	Collar, Tan	1	All but G, Z	-	
		220081-2	Collar, Green	1	G, Z	1	
	33	220104	Stayback Detent	3	All	-	
	34	220080	Body	1	All	-	
	35	220100	Lug Wire	1	All	-	
	36	220093	Locking Lug	9	All	-	
	37	220099	Lug Retainer Ring	1	All	-	
	38	220103	Spring	1	All	-	
	39	220096	Spring Retainer Ring	1	All	-	
	40	220114	Spring	1	All	-	
	41	MS29513-136	Packing	1	All	10	
	42	220120-1	Strainer Housing, Tan	1	All but G, Z	-	
		220120-2	Strainer Housing, Green	1	G, Z	-	
	43	MS29513-226	Packing	1	All	10	
	44	220122-100	Strainer	1	All	-	
	45	220121-1	Strainer Body, Tan	1	All but G, Z	-	
		220121-2	Strainer Body, Green	1	G, Z	-	
	46	GF27026-11-TN	Coupling Half, Female, Tan	1	All but G	-	
		GF27026-11-GN	Coupling Half, Female, Green	1	G	-	
	47	MS27030-6	Gasket	1	All	10	
		220126-6	Gasket, Arctic	1	Z	10	
	48	Left intentionally blank					
	49	GF27029-11-TN	Dust Plug, Tan	1	All but G, Z	-	
		GF27029-11-GN	Dust Plug, Green	1	G,Z	-	
	50	220326	Flow Guide	1	All	-	
-		KD64017-1	Special Tool Kit – contains all five special assembly/disassembly tools needed as shown in Figure 3 of SM64017 to overhaul a basic unit with a diaphragm assembly. (Note: Use -12 for nozzles with piston assembly).				
-		KD64017-2	Kit of parts to upgrade Piston to piston assembly and changes main sleeve seal to Teflon in basic 64017 Nozzle – contains items 6, 6A (2 included – see notes under item 6 above), 6B, 11, 13, 13A, 13B, 20, 26, 26A, 28, 28A, 30, 41, 43 & 47 (normal temperature items only).				
-		KD64017-3	Kit of parts to upgrade diaphragm type control to piston type control assembly and changes main				

Fig	Item	Part Number	Description	Units / Assy	Used on Option	Spares/10 units/Yr
-			sleeve seal to Teflon in 64017Z Nozzle – contains items 6, 6A (2 included – see notes under item 6 above), 6B, 11, 13, 13A, 13B, 20, 26, 26A, 28, 28A, 30, 41, 43 & 47 (low temperature items only).			
-		KD64017-4	Kit of parts to upgrade Piston to piston assembly and changes main sleeve seal to Teflon in 64017B Nozzle – contains appropriate items 6, 6A (2 included – see notes under item 6 above), 6B, 11, 13, 13A, 13B, 20, 26, 26A, 28, 28A, 30, 41, & 43 plus soft goods to replace the parts in the unisex coupling, 64019J.			
-		KD64017-5	Kit of parts to upgrade Diaphragm Assembly to piston assembly and changes main sleeve seal to Teflon in 64017D Nozzle - contains items 6, 6A (2 included – see notes under item 6 above), 6B, 11, 13, 13A, 13B, 20, 26, 26A, 28, 28A, 30, 41 & 43 plus 220709-232 Seal for the D option.			
-		KD64017-6	Kit of parts to upgrade diaphragm to piston assembly and changes main sleeve seal to Teflon in 64017E Nozzle - contains items 6, 6A (2 included – see notes under item 6 above), 6B, 11, 13, 13A, 13B, 20, 26, 26A, 28, 28A, 30, 41 & 43 plus soft goods to replace the parts in the unisex coupling, 64020J.			
-		KD64017-7	Kit of parts to replace the soft goods in the basic 64017 Nozzle that has already been upgraded - contains items 6, 6A (2 included – see notes under item 6 above), 6B, 13A, 20, 28A, 30, 41, 43 & 47 (normal temperature items only).			
-		KD64017-8	Kit of parts to replace the soft goods in the basic 64017Z Nozzle that has already been upgraded - contains items 6, 6A (2 included – see notes under item 6 above), 6B, 13A, 20, 28A, 30, 41, 43 & 47 (low temperature items only).			
-		KD64017-9	Kit of parts to replace the soft goods in the basic 64017 Nozzle that has already been upgraded - contains items 6, 6A (2 included – see notes under item 6 above), 6B, 13A, 20, 28A, 30, 41 & 43 plus soft goods to replace the parts in the unisex coupling, 64019J.			
-		KD64017-10	Kit of parts to replace the soft goods in the basic 64017 Nozzle that has already been upgraded - contains items 6, 6A (2 included – see notes under item 6 above), 6B, 13A, 20, 28A, 30, 41 & 43 plus 220709-232 Seal.			
-		KD64017-11	Kit of parts to replace the soft goods in the basic 64017 Nozzle that has already been upgraded - contains items 6, 6A (2 included – see notes under item 6 above), 6B, 13A, 20, 28A, 30, 41 & 43 plus soft goods to replace the parts in the unisex coupling, 64020J.			
-		KD64017-12	Kit of 4 special tools to repair any 64017 Nozzle with the latest configuration piston assembly. (See Figure 3 less the diaphragm tool).			
-		KD64017-13	Kit of parts for standard nozzles to replace obsolete 220094-1 Seal with items 6 & 6A.			
-		KD64017-14	Kit of parts for arctic nozzles 64017Z to replace obsolete 220094-1 Seal with items 6 & 6A.			
-		KD64017-15	Kit to upgrade nozzles for use in extremely dusty environment. Includes 47484 & 47485.			

Notes:

1. All part numbers beginning with "GF" are interchangeable with those beginning with either "AN" or "MS". If the "GF" is followed by three numbers, it is interchangeable with an "AN" part, otherwise it is interchangeable with an "MS" part of the same number.
2. Spare parts recommended are for a set of ten nozzles being overhauled at a frequency of once each year. The actual frequency of overhaul may be longer or shorter depending upon the number of refueling cycles used. This is intended as a guide only.
3. See SM64031 for kits required along with KD64017-7 to overhaul a 64017F,
4. The 47484 Piston Assembly includes items 13A, 13B; 26A & 29. Also includes replacement parts for items for items 13 (221501 Piston) & 26 (221502 Bushing) for nozzles modified to work in heavy dust conditions.
5. The 47485 Seal Sleeve Assembly includes replaces item 27 and includes replacements for item 28 (221500) & 28A (MS29513-028).
6. There currently is no option to offer this modification in a new nozzle. One can only modify an existing nozzle to obtain this option. If new nozzles of this type are desired, contact Carter for a change in the options.

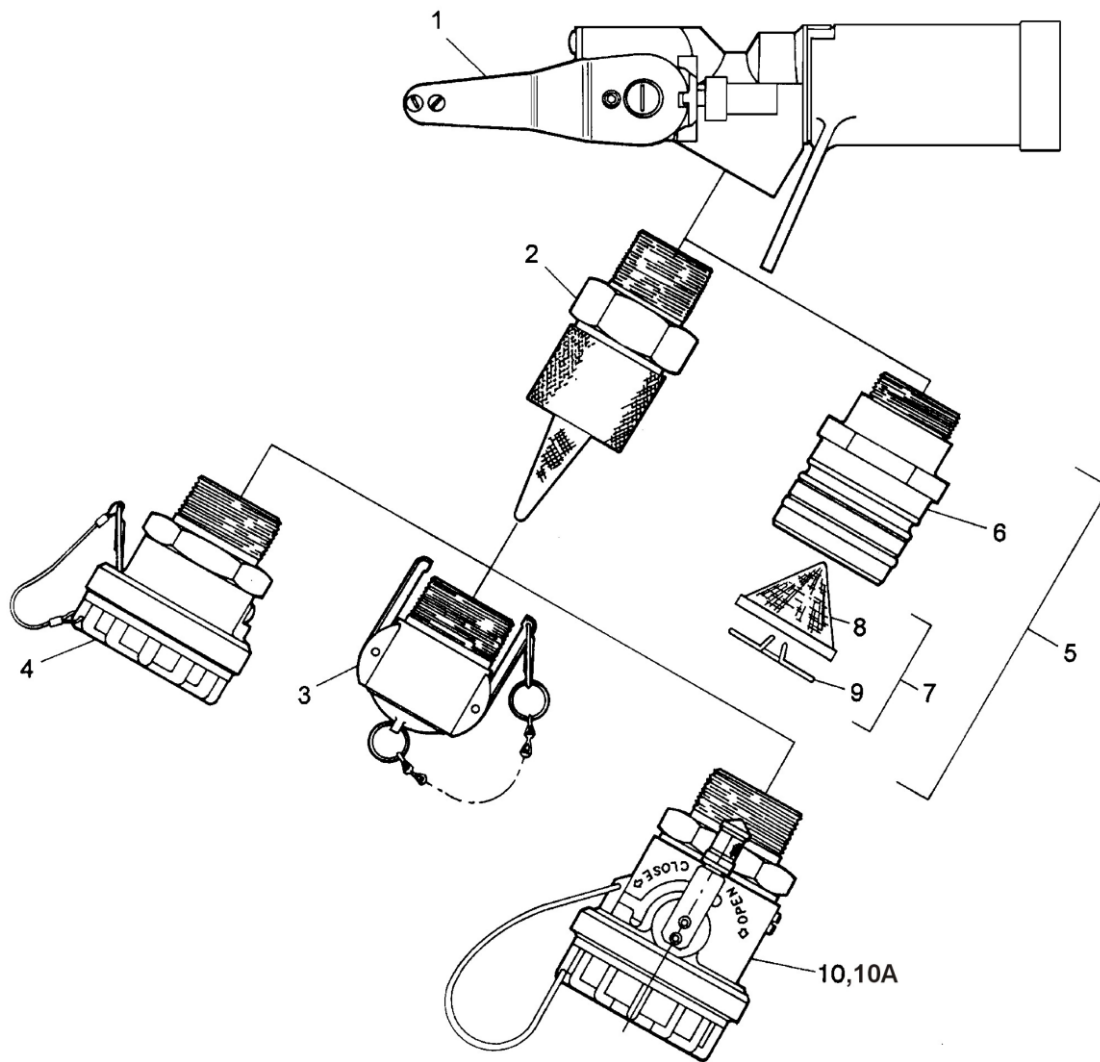
**FIGURE 1 - OPTIONS VIEW**

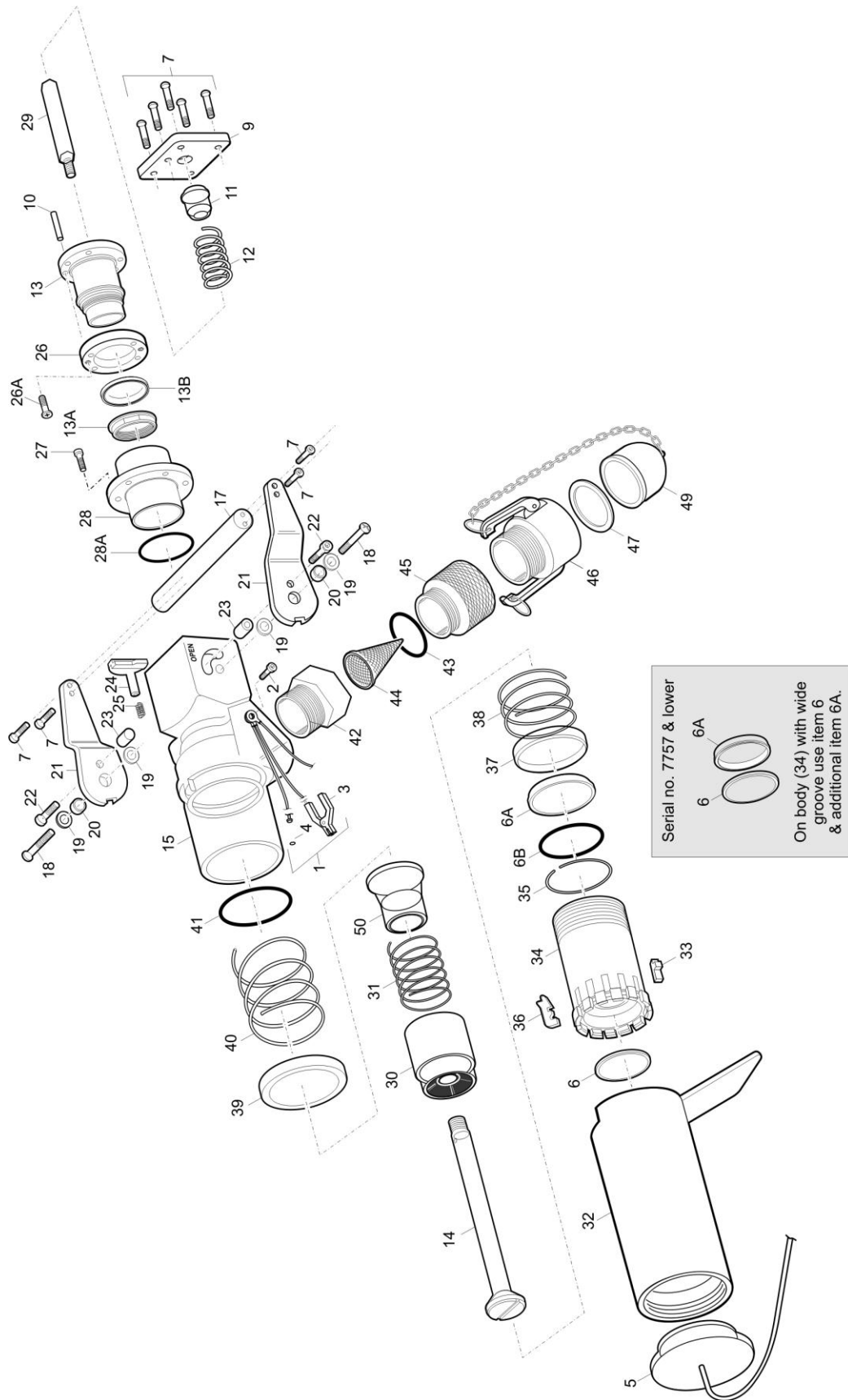
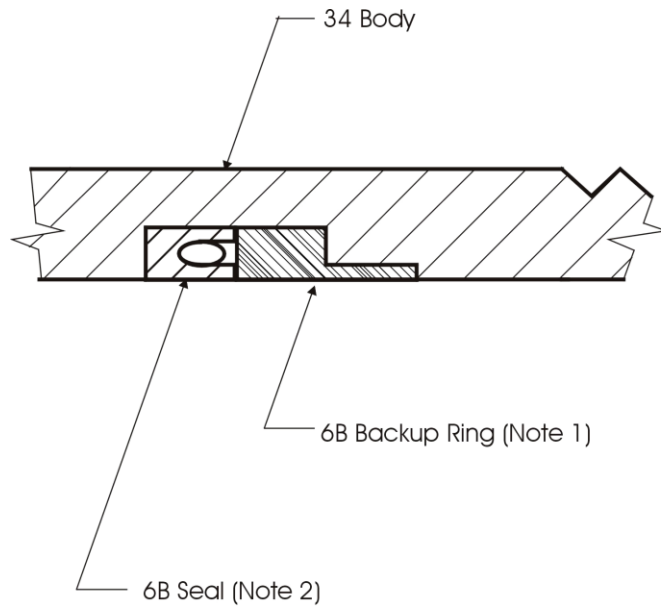

FIGURE 2 - PARTS BREAKDOWN



Notes:

1. Thin lip of Backup Ring (6B) must face toward threaded end of Body (34).
2. Open end of Seal (6A) must face toward threaded end of Body (34). The seal is pressure sensitive and if installed backwards leakage will occur.

FIGURE 2A - MAIN BODY SEAL INSTALLATION

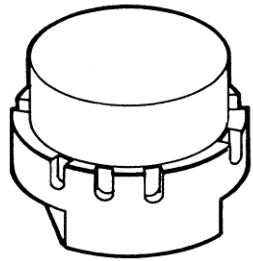

220281

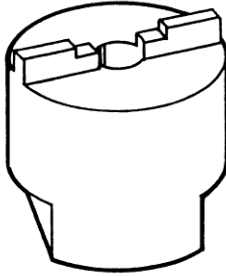

220282

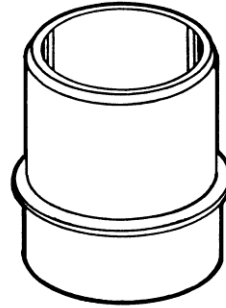

220283

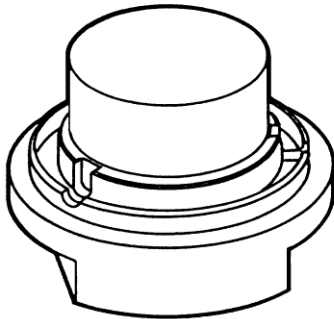

220284

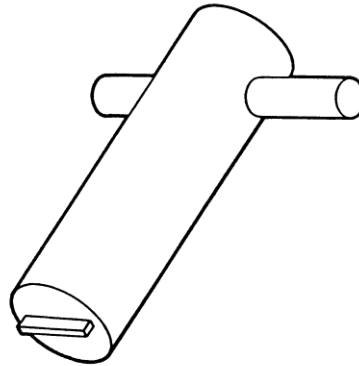

220329

FIGURE 3 - ASSEMBLY TOOLS

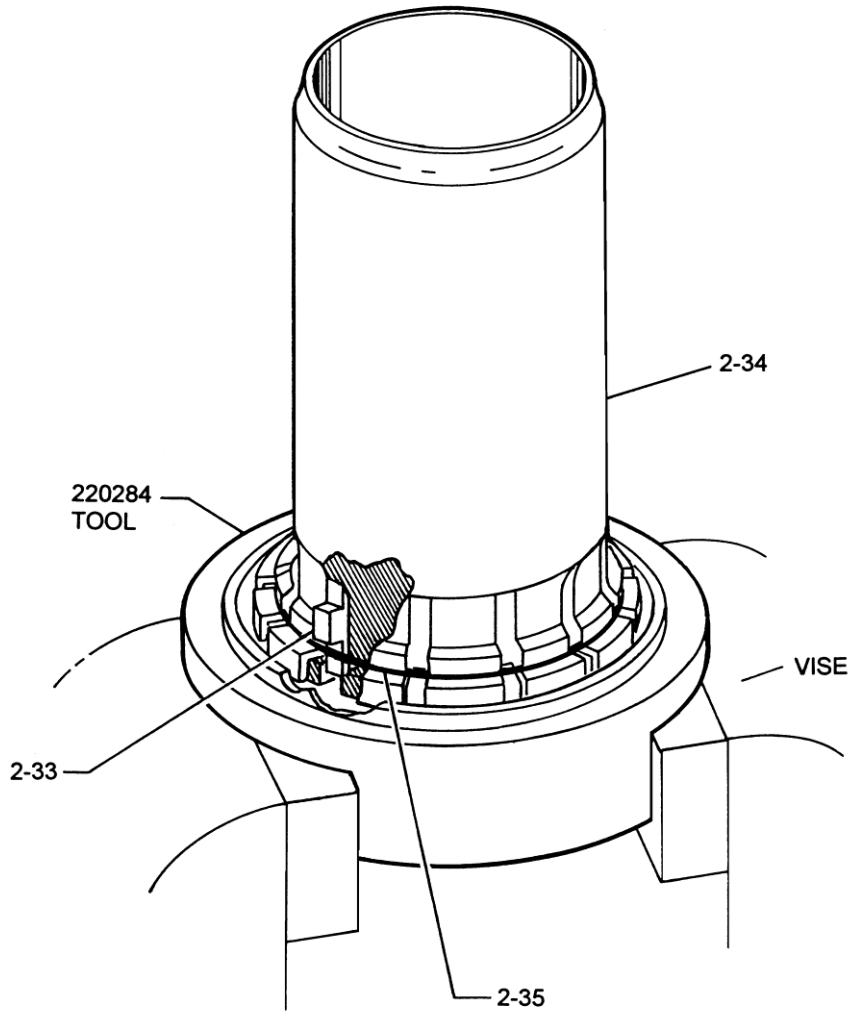

**FIGURE 4 - USE OF 220284 TOOL
TO INSTALL STAY BACK DETENTS (33)**

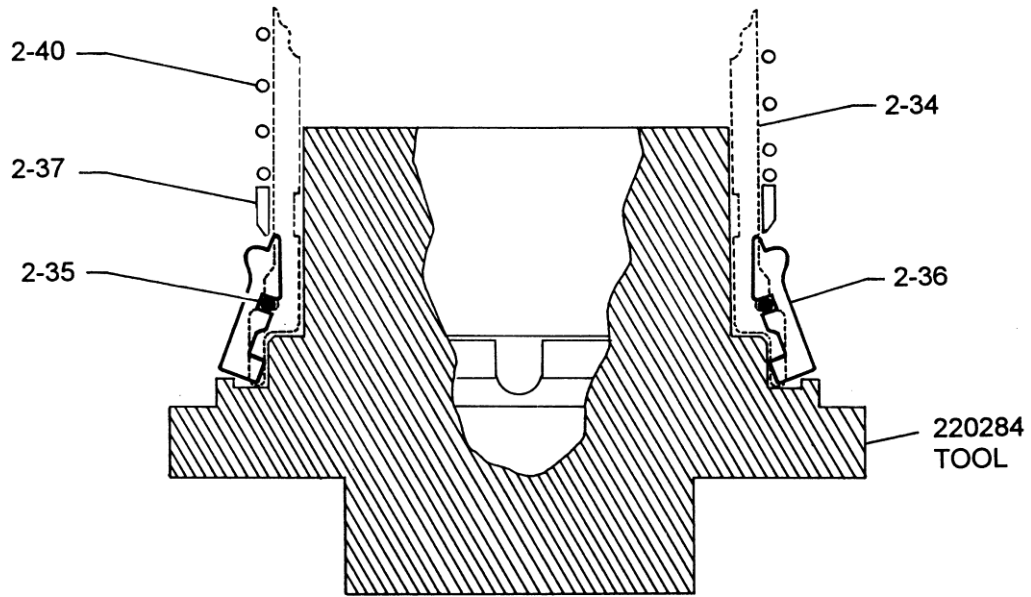

**FIGURE 5 - USE OF 220284 TOOL
TO INSTALL LOCKING LUGS (36)**



Powering Business Worldwide

Eaton
Aerospace Group
Fluid & Electrical Distribution Division
9650 Jeronimo Road
Irvine, CA USA 92618
Ph: (949) 452-9500
Fax: (949) 452-9992